

**Model No.**

**- 8208 -**

**Specifications**

- Height - 72 inches
- Length - 93 inches
- Width - 72 inches
- Weight - 120 lbs.

**p/n 108208**

**Instruction No. 101930**

# FISH TRAP<sup>®</sup>



## VOYAGER

**\*Special**



### - Clam Customer Service Information -

**NOTICE!! - ONCE USED, THIS SHELTER CANNOT BE RETURNED TO THE STORE. IF YOU HAVE A WARRANTY CLAIM, PLEASE CONTACT CLAM CORP. CUSTOMER SERVICE BY EMAIL INQUIREY OR DIRECT BY CALLING:**

- **Customer Service Hrs: - 9am to 4pm, Mon. - Fri. Central Standard Time**
- **Clam Corporation, Inc.**  
**600 Clydesdale Trail**  
**Medina, MN 55340**
- **Phone - 763-231-4120**
- **Fax - 763-231-4121**
- **Email - [customerservice@clamcorp.com](mailto:customerservice@clamcorp.com)**
- **Website - [www.clamcorp.com](http://www.clamcorp.com)**



**- Bill of Materials -**

<b>ITEM</b>	<b>QTY</b>	<b>PART NO.</b>	<b>DESCRIPTION</b>
<b>1</b>	<b>8</b>	<b>101048</b>	<b>BLOCK, SLIDE</b>
<b>2</b>	<b>2</b>	<b>101061</b>	<b>HOLDER, ACCESSORY</b>
<b>3</b>	<b>1</b>	<b>101064</b>	<b>TENT, VOYAGER 2003/04</b>
<b>4</b>	<b>6</b>	<b>101069</b>	<b>ASSEMBLY, CANOPY POLE</b>
<b>5</b>	<b>8</b>	<b>101080</b>	<b>SCREW, 1/4-20 X 1-1/4" TRUSS HEAD</b>
<b>6</b>	<b>14</b>	<b>101081</b>	<b>WASHER, 1/4 FLAT REG CZ</b>
<b>7</b>	<b>30</b>	<b>101082</b>	<b>NUT, 1/4-20 THIN NYLOCK</b>
<b>8</b>	<b>8</b>	<b>101083</b>	<b>CAP, TUBE SPACER</b>
<b>9</b>	<b>6</b>	<b>101088</b>	<b>SCREW, 1/4-20 X 0.75 PTHM CZ</b>
<b>10</b>	<b>1</b>	<b>101095</b>	<b>ROPE, 3/8 DIA X 9 FT POLYPRO</b>
<b>11</b>	<b>1</b>	<b>101116</b>	<b>MOLDING, 3/4 X 118 U-CHANNEL</b>
<b>12</b>	<b>2</b>	<b>101121</b>	<b>ASSEMBLY, PORCH TUBE</b>
<b>13</b>	<b>1</b>	<b>101124</b>	<b>ASSEMBLY, SPREADER, FIXED</b>
<b>14</b>	<b>1</b>	<b>101130</b>	<b>ASSEMBLY, SPREADER 28.75"</b>
<b>15</b>	<b>4</b>	<b>101146</b>	<b>EXTRUSION, 8.78 ALUM</b>
<b>16</b>	<b>8</b>	<b>101147</b>	<b>SCREW, #10 x 1.00 PPHTCHL CZ</b>
<b>17</b>	<b>16</b>	<b>101148</b>	<b>SCREW, #6 X 3/8" PPH BZ</b>
<b>18</b>	<b>2</b>	<b>101167</b>	<b>ASSEMBLY, SPREADER CLAM 2000</b>
<b>19</b>	<b>2</b>	<b>101290</b>	<b>SEAT, BUCKET STYLE, GRAY</b>
<b>20</b>	<b>2</b>	<b>101399</b>	<b>SWIVEL, SEAT</b>
<b>21</b>	<b>8</b>	<b>101429</b>	<b>PLUG, 1.16 DIA TUBE</b>
<b>22</b>	<b>8</b>	<b>101469</b>	<b>SCREW, #14 X 0.75 SLTD HWH HI-LO CZ</b>
<b>23</b>	<b>8</b>	<b>101470</b>	<b>BOLT, 1/4-20 X 0.50 SRHXFL CZ GR5</b>
<b>24</b>	<b>1</b>	<b>101479</b>	<b>TUBE, HOOP, FRONT. 0.875 DIA GALV</b>
<b>25</b>	<b>3</b>	<b>101482</b>	<b>TUBE, HOOP 0.875 DIA ALUM</b>
<b>26</b>	<b>8</b>	<b>101486</b>	<b>SCREW, 1/4-20 X 1.75 PTHM CZ</b>
<b>27</b>	<b>2</b>	<b>101580</b>	<b>SPREADER, ADJUSTABLE</b>
<b>28</b>	<b>1</b>	<b>101584</b>	<b>BRACKET, LEFT CANOPY</b>
<b>29</b>	<b>1</b>	<b>101585</b>	<b>BRACKET, RIGHT CANOPY</b>
<b>30</b>	<b>1</b>	<b>101677</b>	<b>BASE, WINNIE 06-07</b>
<b>31</b>	<b>4</b>	<b>101678</b>	<b>TUBE, SEAT RAIL, WINNIE</b>

- Assembly Diagram -

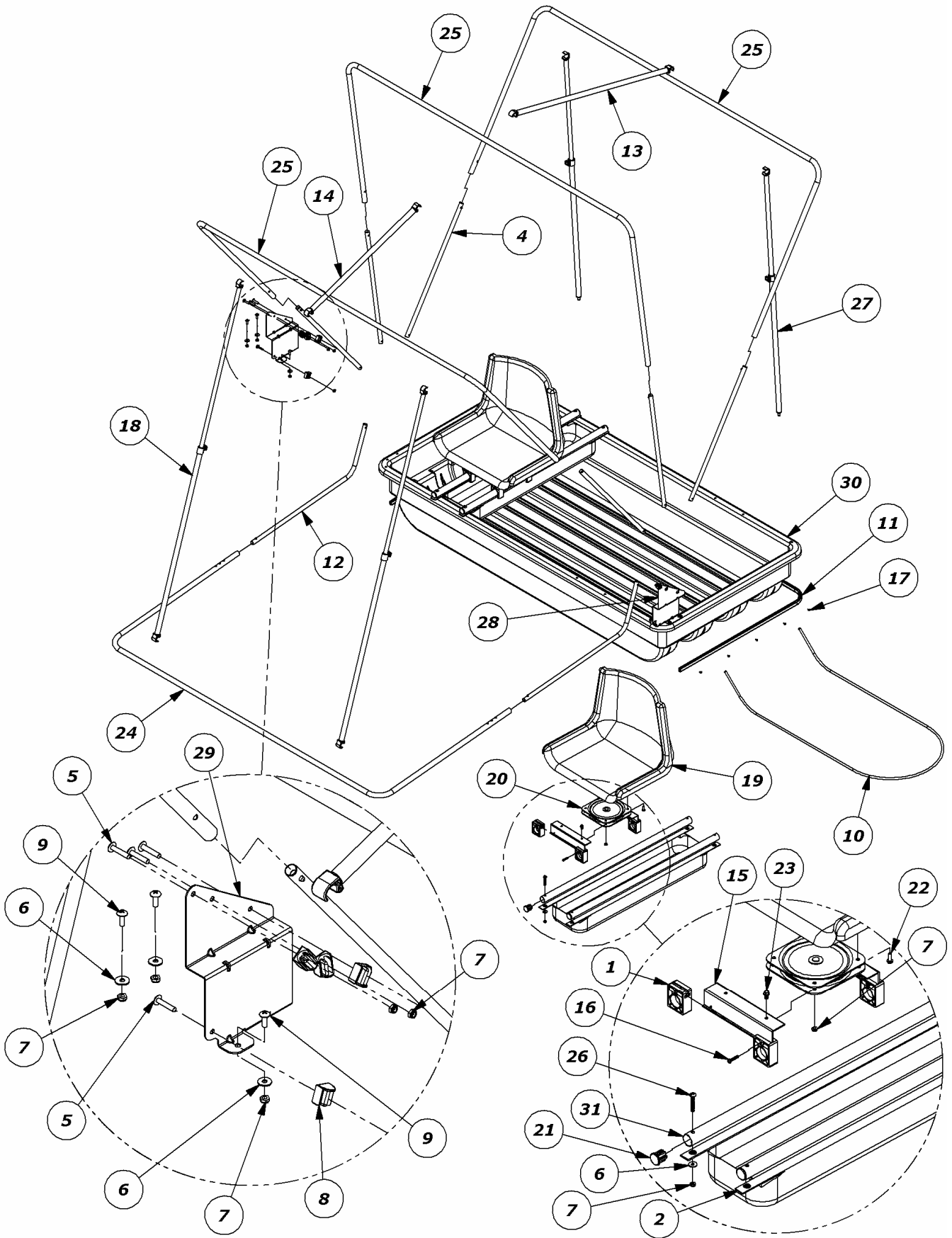

**- Step One -**

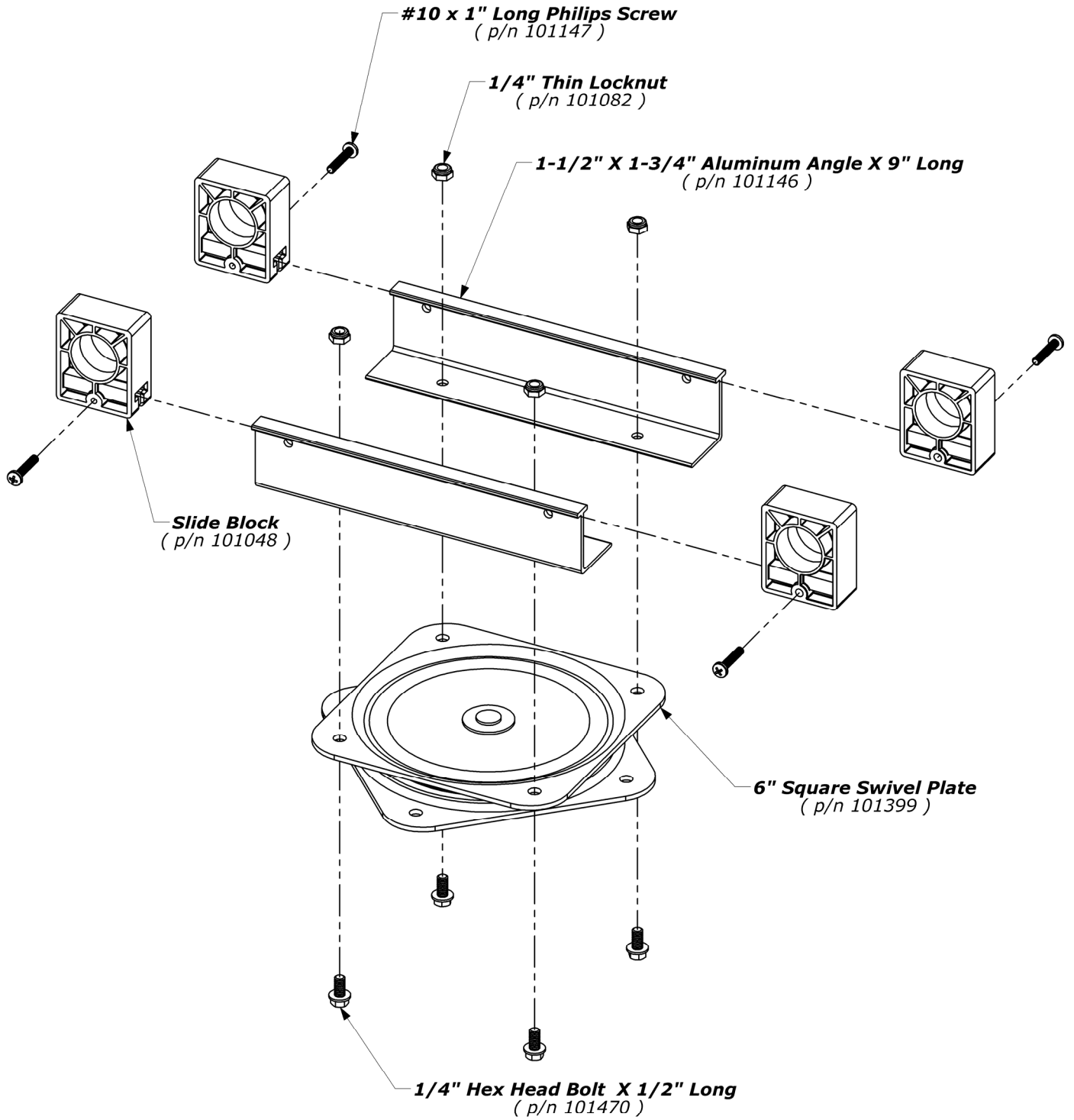

**- Step Two -**

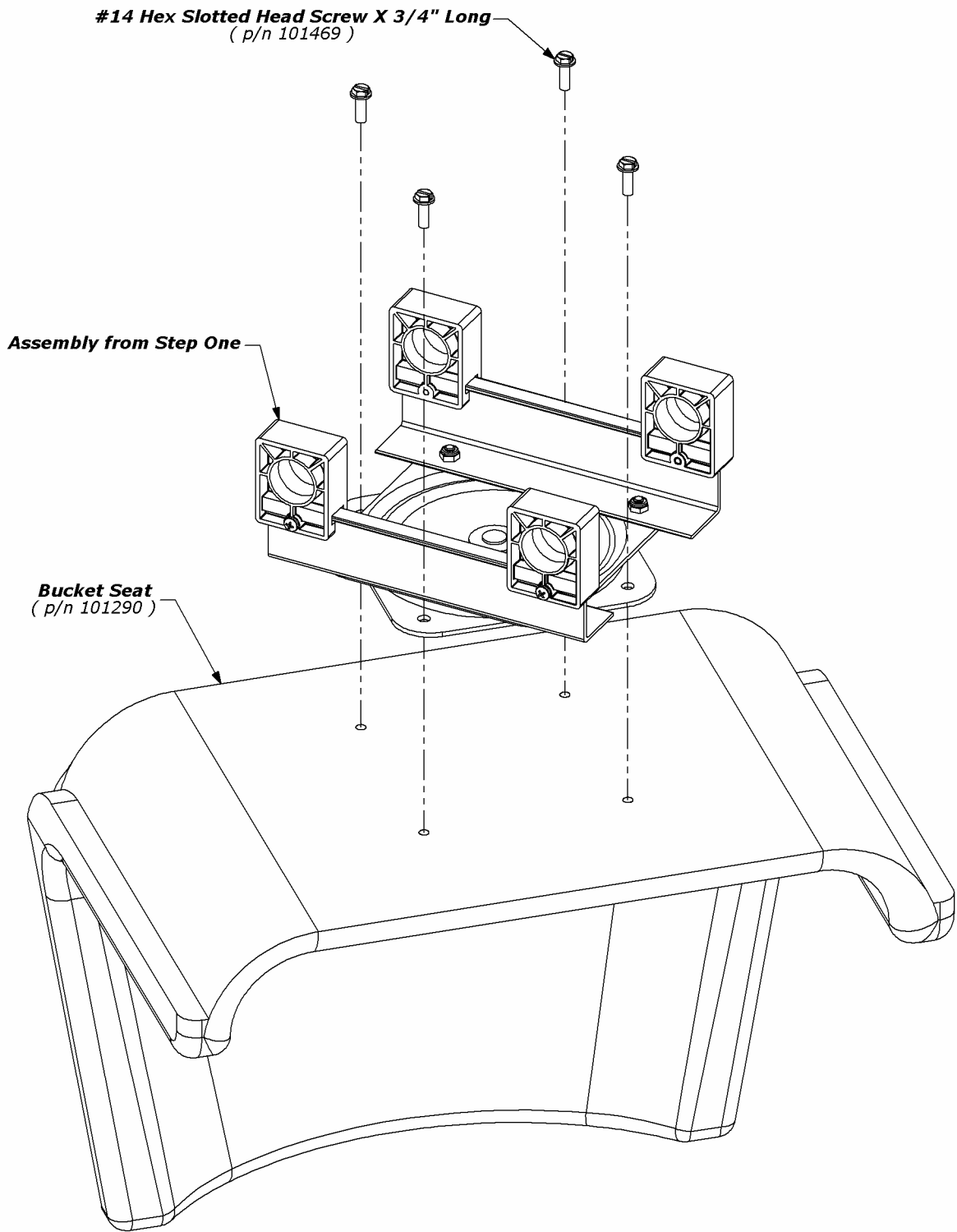

**- Step Three -**

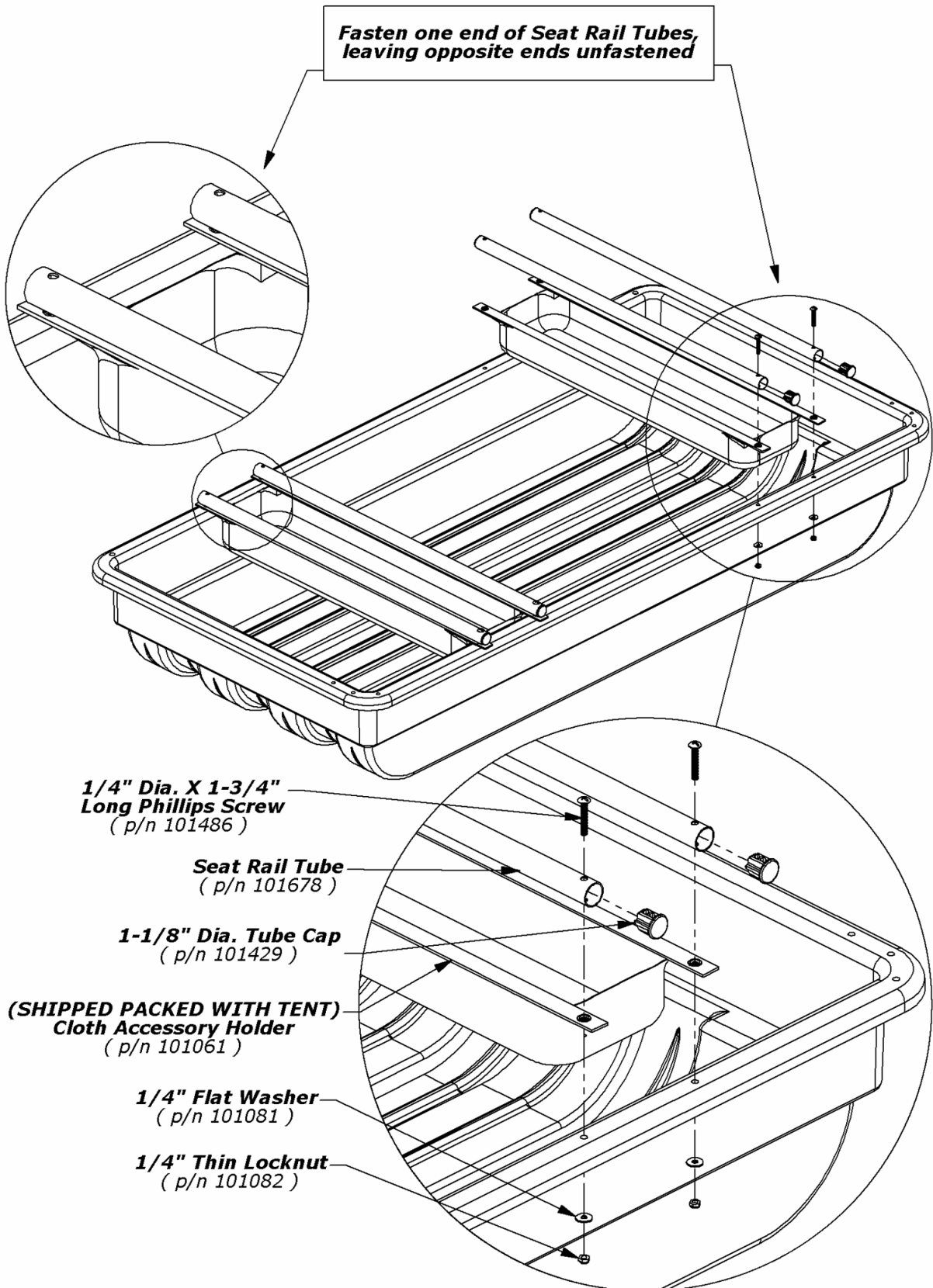

**- Step Four -**

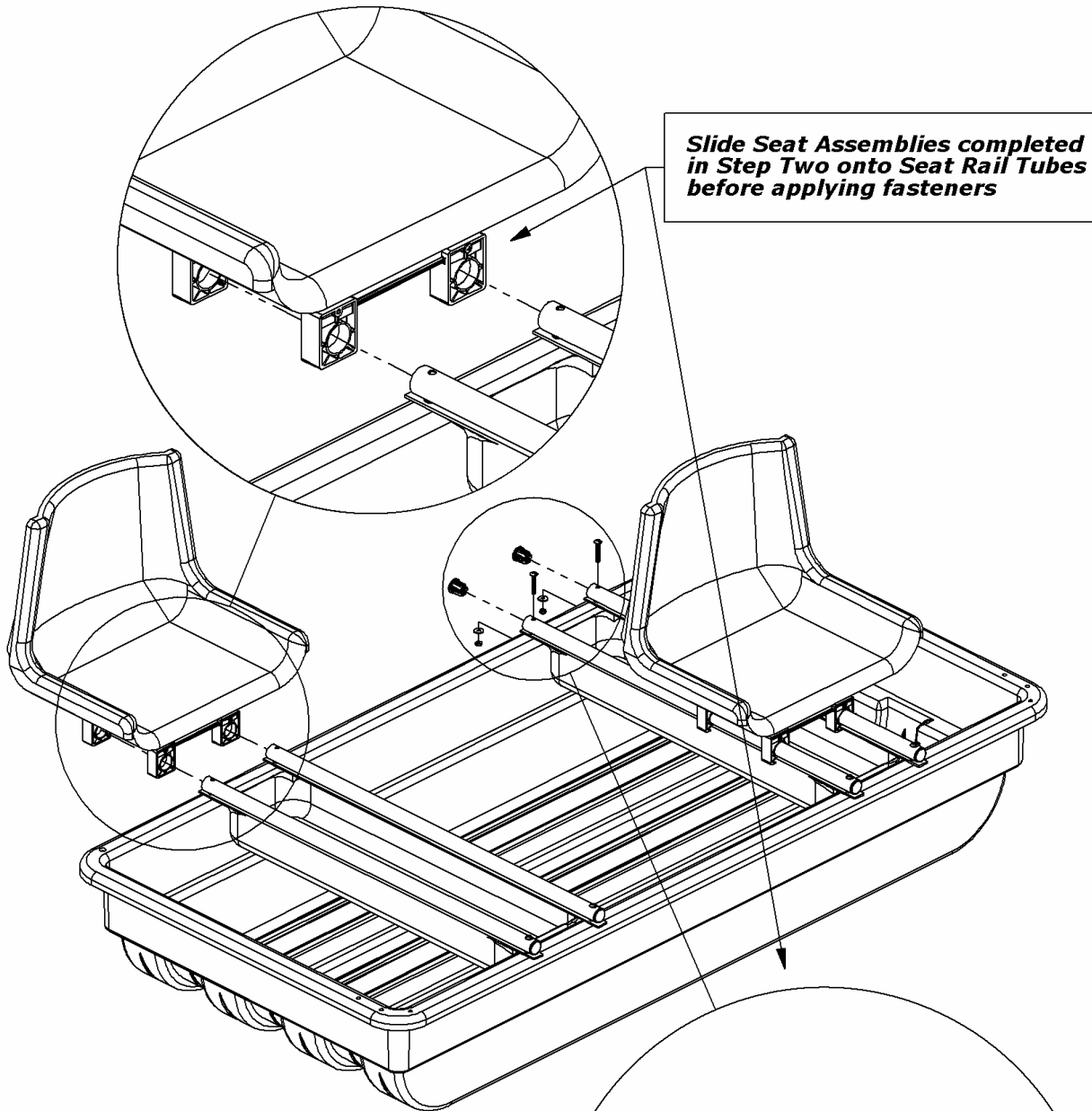

**1/4" Dia. X 1-3/4" Long Phillips Screw**  
( p/n 101486 )

**1-1/8" Dia. Tube Cap**  
( p/n 101429 )

**1/4" Flat Washer**  
( p/n 101081 )

**1/4" Thin Locknut**  
( p/n 101082 )

**- Step Five -**

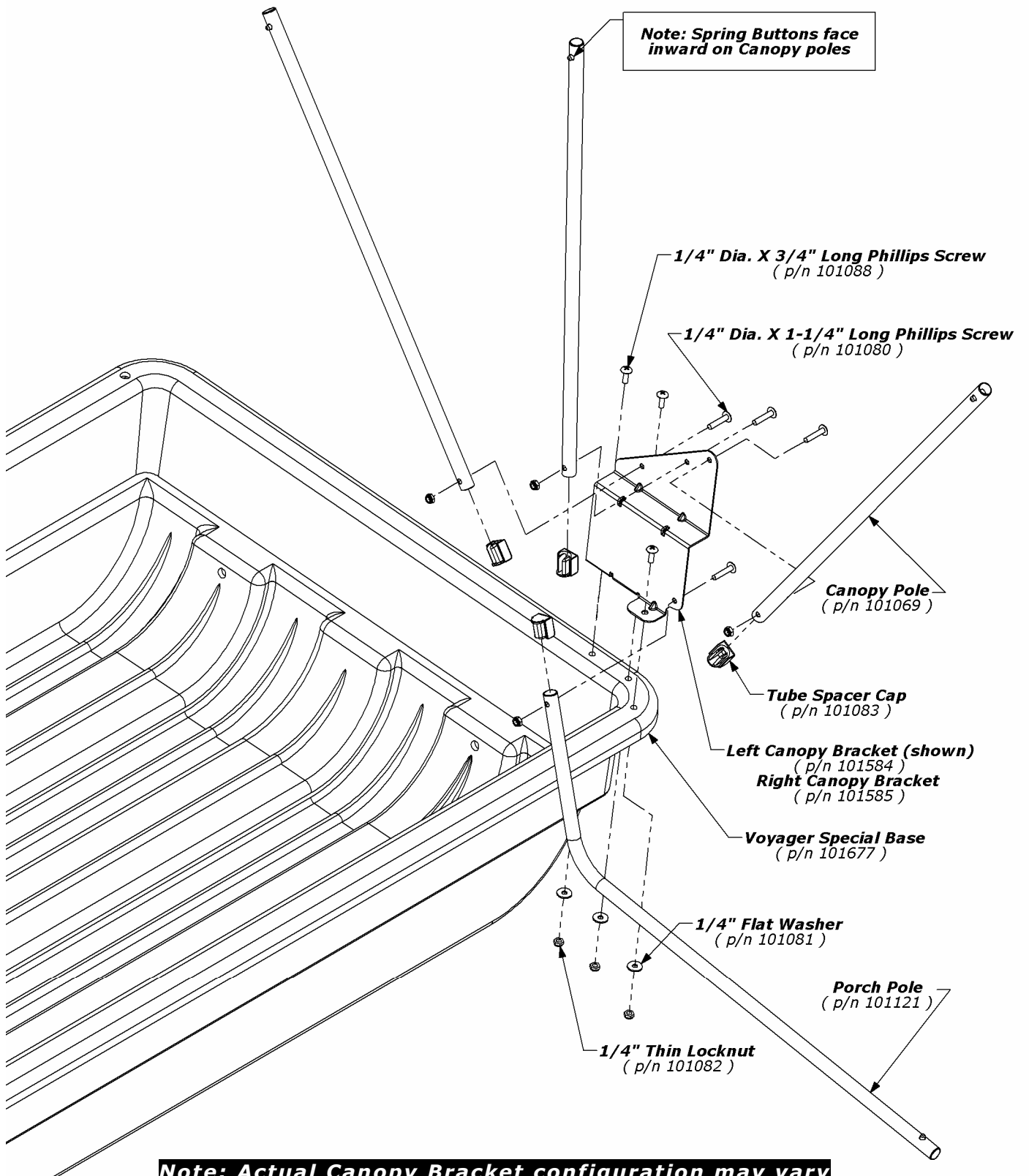

**Note: Actual Canopy Bracket configuration may vary**

**If your Canopy Brackets have four holes near the upper angled edge rather than three hole configuration shown, use the A,B, & D locations stamped on the four hole bracket.**

**Seating has be omitted for clarity**



## - Step Six -

**Slide the Canopy Hoop Poles onto the Canopy Poles until the spring buttons engage the holes near the ends of each Canopy Hoop Pole.**

**Support the first Canopy Hoop Pole as pictured with the Rear Adjustable Spreader Poles (the shorter of the two provided lengths).**

**Lean the two remaining Canopy Hoop Poles against the first.**

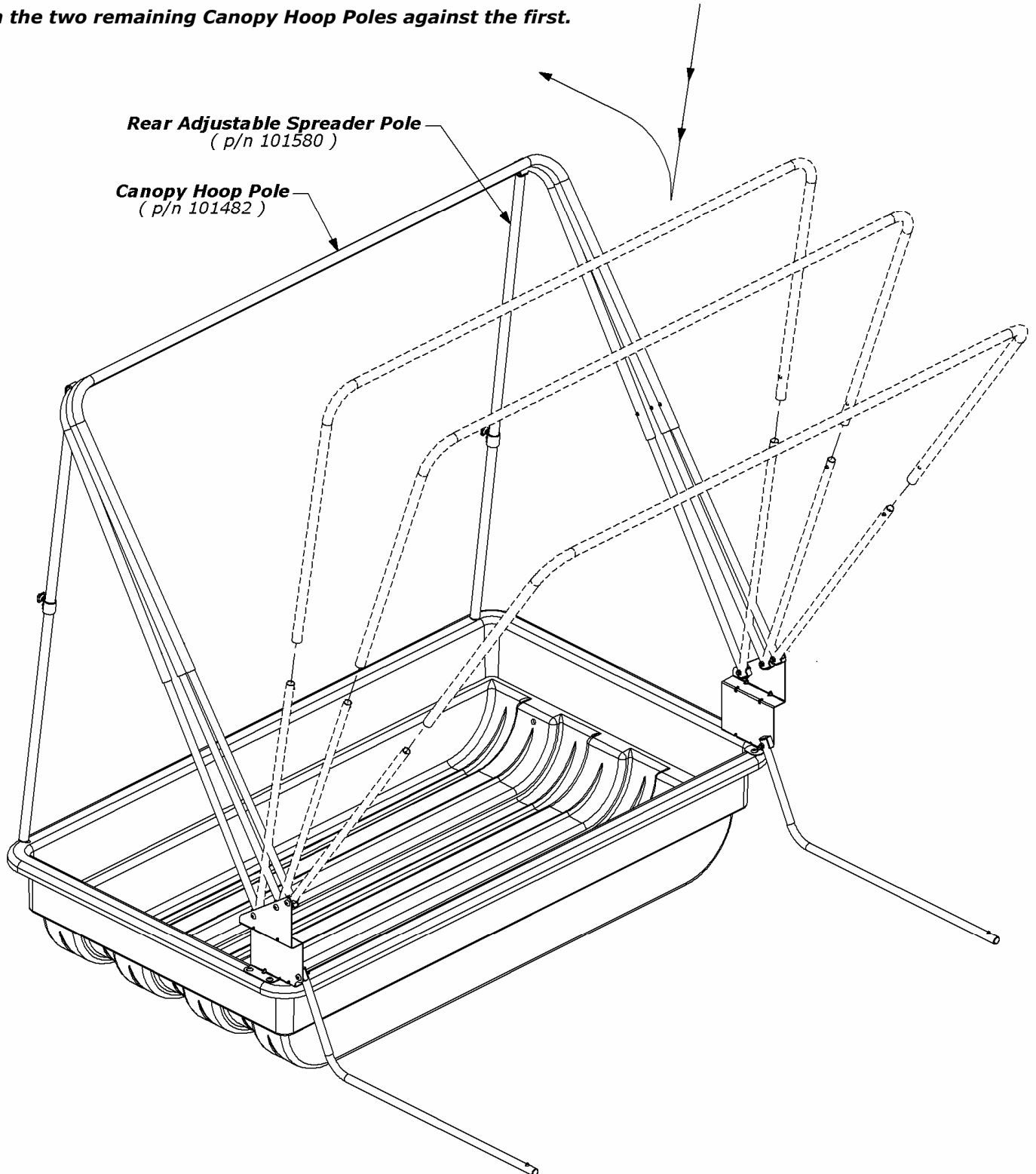

**Note: Seating has be omitted for clarity**

## - Step Seven -

**Drape the Tent over the supported hoops then go inside and spread out the Canopy Hoop Poles, attaching the Roof Velcro as you go.**

**Orient the Porch Hoop Pole so that the holes face upward and then feed the length of the pole through the three Porch Hoop Sleeves sewn on the Tent. Slide the Porch Hoop Pole onto the Porch Poles, engaging the third hole position.**

**Attach the Porch Hoop Velcro on each side of the Tent. Remove the Rear Adjustable Spreader Poles now supporting the hoops to allow the tent to be "set" in the next step.**

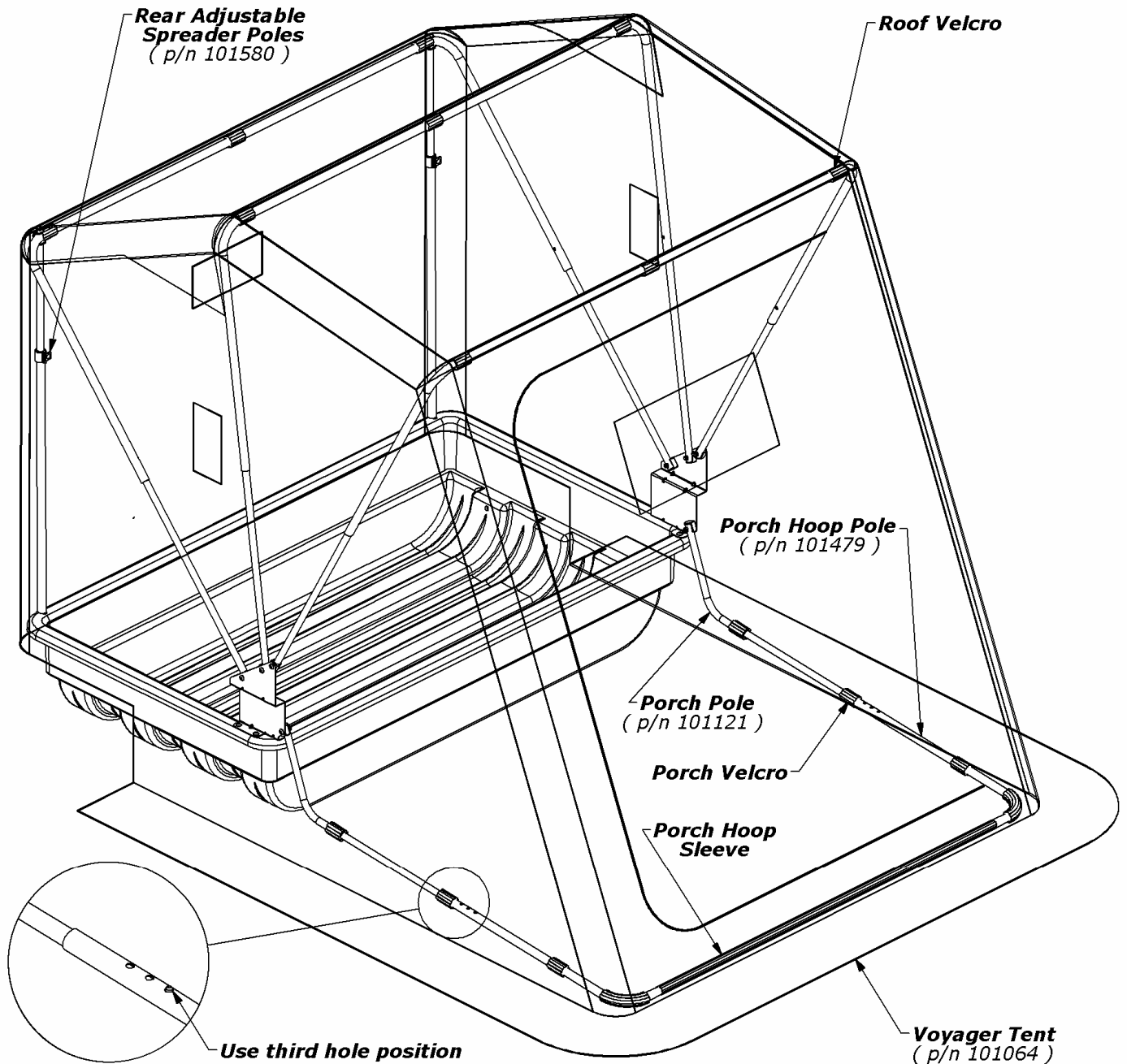

**Note: Seating has be omitted for clarity**

## - Step Eight -

To "set" the tent, grasp the tent material at the rear of the shelter and pull it downward. Observe the porch area of the tent lifting accordingly as you pull. When the U-Channel Molding is correctly installed, the Porch Hoop Pole will lightly touch the floor.

To achieve this condition, start by finding the center of the Molding. From behind the unit, pull the midpoint of the Tent downward and fold the Tent material under the lip of the Base. Then press the midpoint of the molding over the Tent material and Base lip. Continue pressing outward in both directions until you have secured about twelve inches of material to the base.

Having temporarily secured the tent to the base, take a walk around the unit. Readjust the Molding until you have verified the proper Porch Hoop Pole position and also that the Tent sides and corners are properly proportioned.

When satisfied, continue applying the Molding around the shelter, one direction from center and then the other, pulling the material as you go so that surface is relatively wrinkle-free and snug. You may need to trim the Molding ends if they are not equal.

Install the Front, Rear, and Roof Spreader Poles as indicated. Adjust the Front and Rear Spreader Poles to tighten the fit of the tent.

If everything still looks good, secure the Molding with the included #6 Phillips Screws. Evenly space them about every ten to twelve inches, and also put a screw in the center of both corners. Since there aren't any predrilled holes, it's advisable to use a powered driver for this operation.

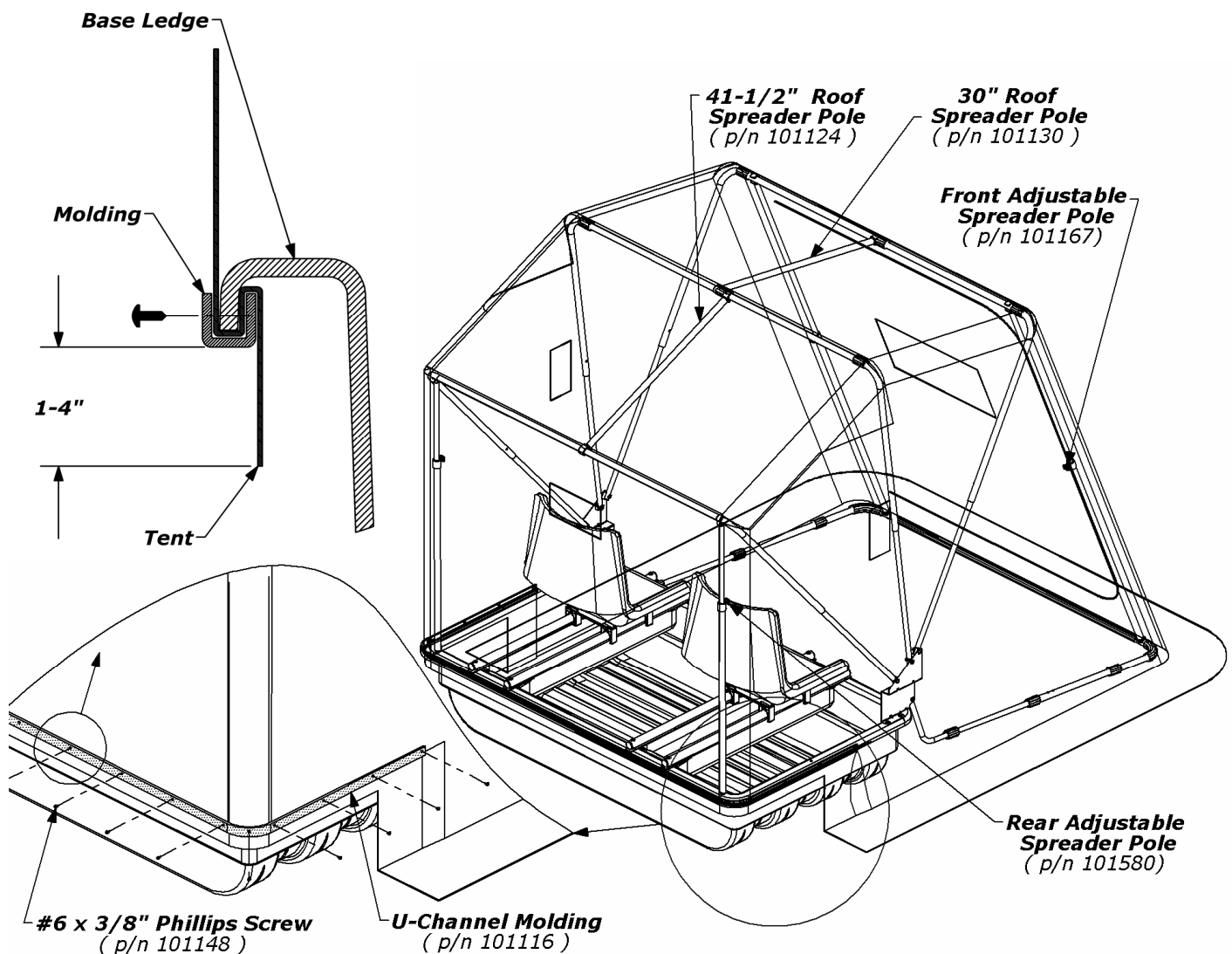

## **- License Holder -**

**If Licensing is required in your area, locate a position on the outside of your tent that you wish to affix the License Holder.**

**Next hold the License Holder in the determined position and use a sharp object to pierce two holes in the tent; going through the grommets of the License Holder.**

**Place the included Snap Buttons through the pierced holes and through the License Holder grommets. Push the Buttons together firmly to secure the holder in place.**

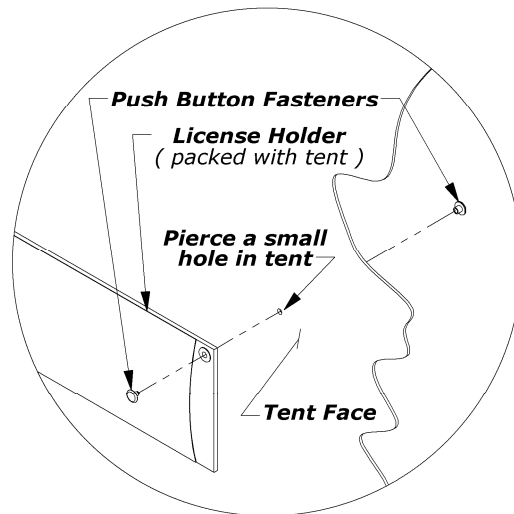

## **- Safety Instructions -**

**Please fully understand and follow all safety instructions as outlined. Failure to do so could result in severe injury or death.**

- **Do not use open flame heaters in your ice shelter. Injury or death may result from fire if tent fabric is exposed to open flame. The tent is not fireproof, but the fabric is treated with a fire retardant that meets CPAI-84 specifications. Application of any foreign substance may render the flame retardant properties ineffective. Ice Armor fabric will melt when contact is made with hot surfaces (i.e., heaters).**
- **Death from asphyxiation may result from use of oxygen depleting heaters. Open all vents for fresh air ventilation.**
- **Never leave shelter unattended when set up.**
- **Due to the increase in traffic (snowmobiles, autos, etc.) on area lakes, ice fishing can be hazardous at night. If you choose to fish at night or in poor visibility conditions, be sure to take precautions with lights or reflectors to show drivers your whereabouts. Night time: exterior reflectors must be visible to reduce risk of collisions.**

## **- Warranty -**

**Clam Corporation, Inc. warrants to the original retail purchaser that all Clams are free from manufacturer's defects for one (1) year from the date of the original purchase. Warranty does not cover cracked windows, tent tears, broken or bent hoops due to high wind weather conditions or unattended use. Clam Corporation will replace or repair any part found defective within the one (1) year time limit. All parts must be returned to Clam Corporation, Inc. Before returning any parts, you must first call or write and acquire a return authorization. All returns must be returned postage-prepaid and include the original cash register receipt (date and purchase price).**

## **- Limitation of Liability -**

**It is expressly understood that Clam Corporation liability for its products, whether due to breach of warranty, negligence, strict liability, or otherwise, is limited to the repair of the product as stated above. Clam Corporation is not liable for any injury, loss, damage, or expense, whether direct or consequential, including but not limited to loss of use, income, profit, or damage to material arising in connection with the sale, installation, use of, inability to use, or the repair or replacement of Clam Corporation products. Clam Corporation reserves the right to make alterations or modifications in its products at any time, which in its opinion, may improve the performance and efficiency of the product. It shall not be obligated to make such alterations or modifications to products already in service.**